

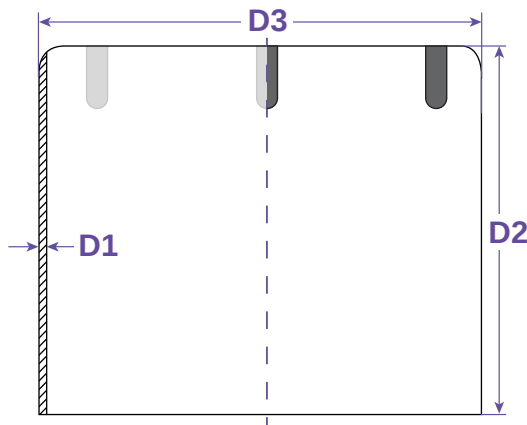

CRIMP FERRULES

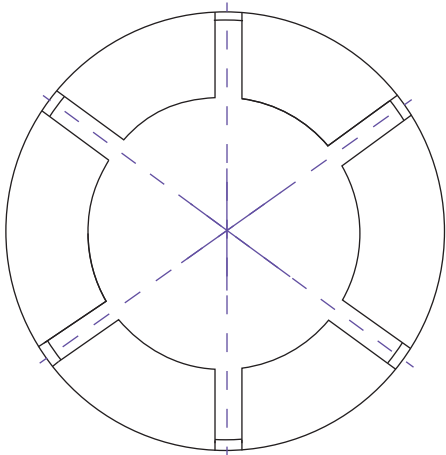

FEATURES & APPLICATIONS:

• General Uses:

A camlock fitting is a type of coupling that is used to connecting hose and or pipes together that transfers liquids, powders and granules. A straight through connection is made that maintains the pipe size and allows the free flow of materials being transferred.

HOSE Size	D1	D2	D3	PART #
1-1/2"				
0.059"	2.79	2-24/64"	F200-224PS	
0.059"	2.79	2-28/64"	F200-228PS	
0.059"	2.79	2-32/64"	F200-232PS	
0.059"	2.79	2-36/64"	F200-236PS	
0.059"	2.79	2-40/64"	F200-240PS	
0.059"	2.79	2-44/64"	F200-244PS	
0.059"	2.79	2-48/64"	F200-248PS	
0.059"	2.79	2-52/64"	F200-252PS	
0.059"	2.79	2-56/64"	F200-256PS	
0.059"	2.79	2-60/64"	F200-260PS	
0.059"	2.79	3"	F200-300PS	
2-1/2"				
0.059"	3.11	2-56/64"	F250-256PS	
0.059"	3.11	3"	F250-300PS	
0.059"	3.11	3-4/64"	F250-304PS	
0.059"	3.11	3-8/64"	F250-308PS	
0.059"	3.11	3-12/64"	F250-312PS	
0.059"	3.11	3-16/64"	F250-316PS	
0.059"	3.11	3-20/64"	F250-320PS	
0.059"	3.11	3-24/64"	F250-324PS	
0.059"	3.11	3-28/64"	F250-328PS	
0.059"	3.11	3-32/64"	F250-332PS	
0.059"	3.11	3-36/64"	F250-336PS	
0.059"	3.11	3-40/64"	F250-340PS	
3"				
0.098"	3.94	3-32/64"	F300-332PS	
0.098"	3.94	3-36/64"	F300-336PS	
0.098"	3.94	3-40/64"	F300-340PS	
0.098"	3.94	3-44/64"	F300-344PS	
0.098"	3.94	3-48/64"	F300-348PS	
0.098"	3.94	3-52/64"	F300-352PS	
0.098"	3.94	3-56/64"	F300-356PS	
0.098"	3.94	3-60/64"	F300-360PS	
0.098"	3.94	4"	F300-400PS	
0.098"	3.94	4-8/64"	F300-408PS	
0.098"	3.94	4-16/64"	F300-416PS	
4"				
0.098"	4.19	4-24/64"	F400-424PS	
0.098"	4.19	4-32/64"	F400-432PS	
0.098"	4.19	4-36/64"	F400-436PS	
0.098"	4.19	4-40/64"	F400-440PS	
0.098"	4.19	4-44/64"	F400-444PS	
0.098"	4.19	4-48/64"	F400-448PS	
0.098"	4.19	4-52/64"	F400-452PS	
0.098"	4.19	4-56/64"	F400-456PS	
0.098"	4.19	4-60/64"	F400-460PS	
0.098"	4.19	5"	F400-500PS	
0.098"	4.19	5-4/64"	F400-504PS	
5"				
0.120"	---	5-60/64"	F500-560PS	
6"				
0.118"	5.67	6-4/64"	F600-604PS	
0.118"	5.67	6-40/64"	F600-640PS	
0.118"	5.67	6-56/64"	F600-656PS	
0.118"	5.67	6-60/64"	F600-660PS	
0.118"	5.67	7"	F600-700PS	
0.118"	5.67	7-4/64"	F600-704PS	
0.118"	5.67	7-12/64"	F600-712PS	

HOSE Size	D1	D2	D3	PART #
1/2"				
0.059"	1.41	56/64"	F050-056PS	
3/4"				
0.059"	2.14	1-4/64"	F075-104PS	
0.059"	2.14	1-8/64"	F075-108PS	
0.059"	2.14	1-12/64"	F075-112PS	
0.059"	2.14	1-16/64"	F075-116PS	
0.059"	2.14	1-20/64"	F075-120PS	
1"				
0.059"	2.29	1-28/64"	F100-128PS	
0.059"	2.29	1-32/64"	F100-132PS	
0.059"	2.29	1-36/64"	F100-136PS	
0.059"	2.29	1-40/64"	F100-140PS	
0.059"	2.29	1-44/64"	F100-144PS	
0.059"	2.29	1-48/64"	F100-148PS	
0.059"	2.29	1-52/64"	F100-152PS	
1-1/4"				
0.059"	2.32	1-52/64"	F125-152PS	
0.059"	2.32	1-56/64"	F125-156PS	
0.059"	2.32	1-60/64"	F125-160PS	
1-1/2"				
0.059"	2.36	1-56/64"	F150-156PS	
0.059"	2.36	1-60/64"	F150-160PS	
0.059"	2.36	2"	F150-200PS	
0.059"	2.36	2-4/64"	F150-204PS	
0.059"	2.36	2-8/64"	F150-208PS	
0.059"	2.36	2-12/64"	F150-212PS	
0.059"	2.36	2-16/64"	F150-216PS	
0.059"	2.36	2-20/64"	F150-220PS	
0.059"	2.36	2-24/64"	F150-224PS	
0.059"	2.36	2-28/64"	F150-228PS	

WARNING:

Cam & Groove Couplings should **NOT** be used with any compressed gas, including steam or air. Metal fittings should **NOT** be used with Polypropylene Cam & Groove. Dust Caps and Dust Plugs are **NOT** designed for pressure applications.

Note: All Seal Fast Cam & Groove Stainless Bodies are 316 Investment with 304 Handles.

TITLE CRIMPTEK - FERRULES

DISCLAIMER All drawings and specifications are subject to change without notice. Drawings represent general dimensions of our products. Seal Fast cannot guarantee the dimensions in the drawing will exactly match those in the drawing. This drawing is the property of Seal Fast Inc. Copying or reproduction of this drawing is expressly prohibited.	MATERIAL PLATED IRON
DRAWING NOT TO SCALE	PART # F...-...PS

